

# CELLULAR SASH

## FOR WOOD AND COMPOSITE WINDOWS



### Open Your Window with Innovative Design



565 Cedar Way • Oakmont, PA 15139 • 1-800-424-3573 • [www.chelseabuildingproducts.com](http://www.chelseabuildingproducts.com)

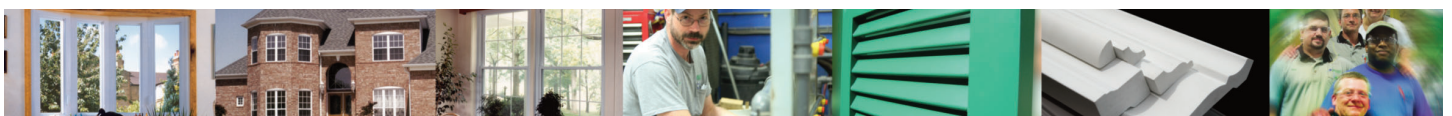

# CELLULAR SASH

## FOR WOOD AND COMPOSITE WINDOWS

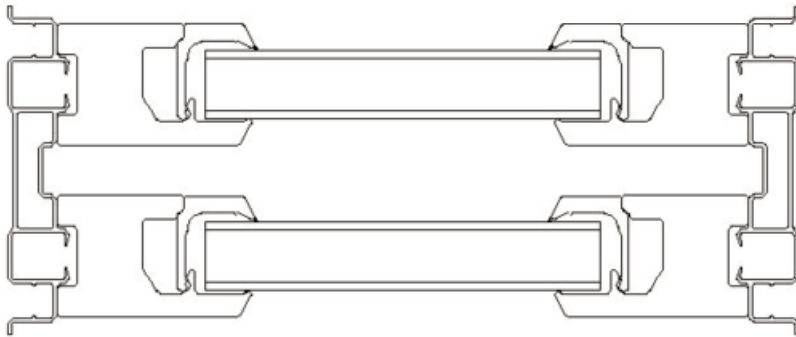

Note: Adapter not included. Shown for illustrative purposes.

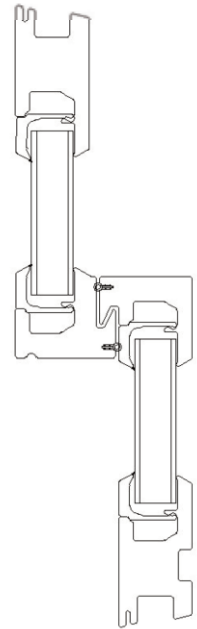

### Cellular Sash Features

- Ideal solution for Double Hung sash replacement.
- Extruded (not machined) using the finest, exterior grade cellular PVC material.
- Strong and durable material resists splitting and cracking.
- Low maintenance and long-lasting beauty.
- Highly weatherable material is not affected by rain, snow, or salt and is resistant to mold and mildew.
- The sash parts are resistant to insects, including termites.
- Finished lineal lengths are ready to put into your window production line. Save time, labor and finishing costs.
- Energy efficient cellular sashes will be a feature for consumer sales.
- The specially formulated compound used to extrude the cellular sash is UV-resistant.
- Traditional wood-look complements any design.
- No painting necessary since all profiles have a matte, non-gloss finish. However, custom painting can add a decorative touch to your window. Oil or latex paints made for vinyl products are recommended. Simply follow the paint manufacturers application instructions and recommendations.
- Accepts 3/4" and 11/16" insulated glass.



Interlocking meeting rails with optional weatherstrip provides additional protection against air infiltration between sash.



Upgrade your window's appearance with optional SDL bars.